



A Model of Footstep Generator

Great O. Abadah ^{a*}

^a *Department of Mechanical Engineering, Federal University of Petroleum Resources, Effurum, Nigeria.*

Author's contribution

The sole author designed, analyzed, interpreted and prepared the manuscript.

Article Information

DOI: 10.9734/JERR/2023/v24i5816

Open Peer Review History:

This journal follows the Advanced Open Peer Review policy. Identity of the Reviewers, Editor(s) and additional Reviewers, peer review comments, different versions of the manuscript, comments of the editors, etc are available here: <https://www.sdiarticle5.com/review-history/93991>

Original Research Article

Received: 01/10/2022

Accepted: 03/12/2022

Published: 23/02/2023

ABSTRACT

Sufficient energy generation is one the key amenities lack in Nigeria. Also, the effect of fossil fuel forced to seek for alternative energy sources. In order to solve the problem of energy in Nigeria and to achieve zero carbon emission, a footstep general prototype was developed using reversed manufacturing. Reversed manufacturing method was aborted in order to conserved energy, material and the environment and minimize waste especially e- waste. The performance of machine was evaluated based on the stepping pressure of humans that weigh between 50kg to 120kg.

Keywords: Footstep generator; Nigeria; fossil fuels; transmission mechanism.

1. INTRODUCTION

The growth and increase in world population and industrialization, has skyrocketed the demand for energy increase exponentially. The quantity of energy available to a man to a large extent determines the quality of his life. As a result, there is a growing concern over the exhaustion

of the available fossil fuel resources in the nearest future with the rapid rise in their consumption rate over the past decades [1]. Emission of carbon from fossil fuels contribute a major portion of the environmental pollutions leading to climate change and global warming. Conclusively, man's over reliance on fossil fuel for power production needs to be reduced

*Corresponding author: Email: greatabadah@gmail.com;

drastically with a goal of minimizing carbon emissions. The call for solutions to energy demand problems cannot be over stressed as the global energy demand is on the increase [1,2]. Embracing alternative power generation technologies such as foot-step power generation system which utilizes waste energy from human locomotion would help reduce the emission of greenhouse gas.

The footstep power generation system if adopted in Nigeria and perhaps globally would help combat the challenges associated with traditional energy supply and usage. There is also a need for a renewable energy as a major source for power generation meet the global energy demand.

This paper reported the design and fabrication of a footstep power generating system which uses a chain drive, gear system as its power transmission mechanism and likewise evaluated its performance and energy efficiency.

2. MATERIALS AND METHODS

Stainless steel of 200 MPa yield strength was used for the generator based, pressure plate and structure so that it could withstand high working stress and vibration; Akinnawo O. and Alare T. reversed manufacturing method [3] was adopted in the selection of material used in the development of this generator model. The dynamo, helical spring and chain drive was gotten from straps yard likewise 80% of the stainless steel used this thereby reduced the cost of production by 30%. Akinnawo O. and Alare T. method of material recovery should be adopted in prototype development or unit production. This because it give a synergy between material, waste, energy and environment [4] and saves cost of production.

2.1 Working Principle

This project built a prototype of a footstep power generating system using a chain drive mechanism and a dynamo. Power is generated by applying pressure on the metal plate suspended by four springs. The oscillating motion of the springs causes the chain drive to rotate the dynamo at high speed and electric power is generated which is then store in a 12v lithium ion battery.

2.2 Footstep Design

The footstep is made a pressure plate or the foot area where the pressure is applied by foot or

feet and an helical spring as the power transmission medium and four supports with $7854 \times 4 = 31416 \text{mm}^2$ total weld area, yield strength = 200N/mm^2 , factor of safety = 2.5, the maximum load is 2.5 MN and the maximum pressure is 80MPa. The helical spring has a diameter (d) of 2mm, a spring index (c) of $(0.56d)^{1/3} = 1.041$ and a mean diameter (D) of $c \times d = 2.1 \text{mm}$ [5-10] and a maximum Induced shear stress of 1988.71MPa [11]. The spring transmit a oscillating motion to the chain and sprocket drive.

2.3 The Chain and Sprocket Drive

The chain and sprocket drive is the main transmission medium of the footstep generator. It transmit power and motion from the footstep to the dynamo (generator) at high speed. The number of teeth of the driver sprocket is 100 and the driven sprocket has 10 teeth with the same pitch. The velocity ratio of the drive is 10 [12,11]. The chain ad sprocket drive convert the oscillating motion of the spring into rotational motion.

2.4 Electrical Accessories

The footstep generator have a 12v lithium ion battery charged by a dynamo generator of maximum power 20w, 300rpm with an electric bulb.

3. RESULTS AND DISCUSSION

When we had finished the design process, we fabricated the individual components (the base plate, steel rods (4), helical compression springs, chain and sprocket, dynamo and the pressure plate.), after which we placed the steel rods on the base plate and installed the chains alongside the geared motor all of which were coupled using bolts and nuts. Finally, we attached the pressure plate to the steel rods inside which we had already fixed the helical compression springs. After the assembly of all the components on the base plate, human load ranging from 50kg to 102kg were applied on the pressure plate and the power output for variable loads was obtained using an ammeter and properly recorded.

This prototype was properly tested and the amount of power generated when ten (10) persons stepped on the system. The weights of these persons were carefully recorded and the amount of power generated by each person are

carefully presented in Table 1. It is important to note that the power output of this system depends on the capacity of the geared motor.

Using: force*distance = m*g*d
 Where: m= mass
 g= gravitational force d= length of the spring
 d= length of the spring

Table. 1. Showing the power output generated when each weight is applied on the pressure plate

S/N	Weight of the body (Kg)	Power output (Watt)
1.	50	2.4525
2.	63	3.0915
3.	68	3.3354
4.	75	3.6787
5.	79	3.8750
6.	84	4.1202
7.	88	4.3164
8.	90	4.4145
9.	97	4.75785
10	102	5.0031

3.1 Principle of Operation of the Footstep Power Generation System

As shown in Table 1, the footstep power generating system base plate should be placed on a flat hard surface to avoid sinking and also to achieve maximum result. To initiate the power generation process, individuals would have to step on the pressure plate with a foot or both which will cause a compression motion of the springs deflecting the chain from its initial position, thereby rotating the dynamo. When you lift your foot from the pressure plate, power is generated and the chain mechanism would

return to its initial position with the help of the suspension springs.

4. DISCUSSION AND CONCLUSION

From the Table 1, we observed that the values of the power output increases with increase in weight applied. In order to optimize renewable energy, irreversibilities and exergy destruction must be minimized [13,2] To achieve this, there must be a continuous foot stepping, we evaluate the energy generated if the footstep generator was installed in a public gathering like the Madonna University Business Center. Suppose this system was installed in the business center in the school premises where a minimum of ten (10) persons walk-in every five (5) minutes and they take a minimum of ten (10) footsteps. Using the recorded weights above, the power generated every five (5) minutes is shown in the Table 2.

Table 2, illustrates power generated per person entering Madonna business center every five minutes. Assuming the business center is open for nine hours on every working day, the net power generated from human locomotion within the premises on an average day baring very busy and less busy days can be calculated mathematically by;

$$\text{Working hours* power generated per person* time}$$

$$9* 390.45 * 12 = 42.2 \text{ kW}$$

One of the main advantages of the project is that it does not require intense and regular maintenance. Other mechanisms like rack and pinion, piezometer and sliding crank mechanism can also be used in generating electricity using footstep.

Table 2. showing the power generated per person entering the Madonna business center every five minutes

S/n	Weight(kg)	Power output (watt)	Power output per five(5) minutes
1	50	2.4525	24.525
2	63	3.0915	30.915
3	68	3.3354	33.354
4	75	3.67872	36.7872
5	79	3.87495	38.7495
6	84	4.1202	41.202
7	88	4.3164	43.164
8	90	4.4145	44.145
9	97	4.75785	47.5785
10	102	5.0031	50.031
TOTAL			390.45



Fig. 1. Power generation technology

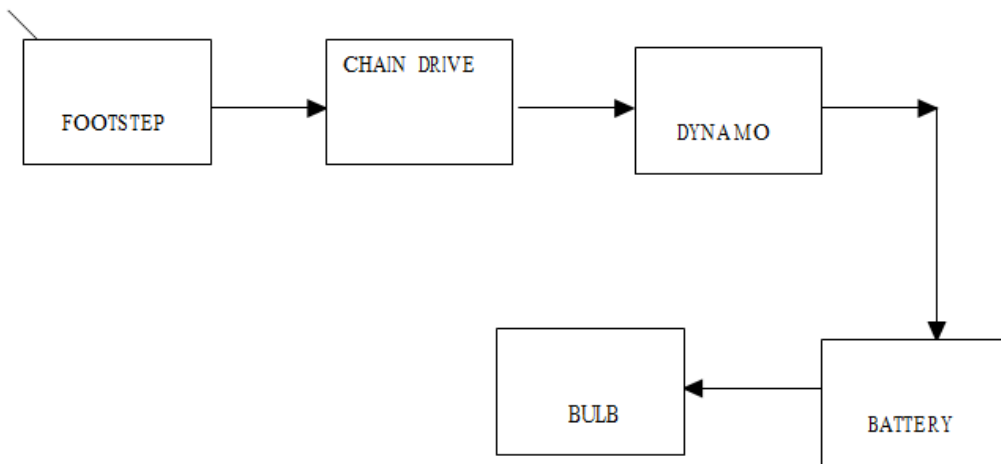

Fig. 2. Block diagram of the footstep generator

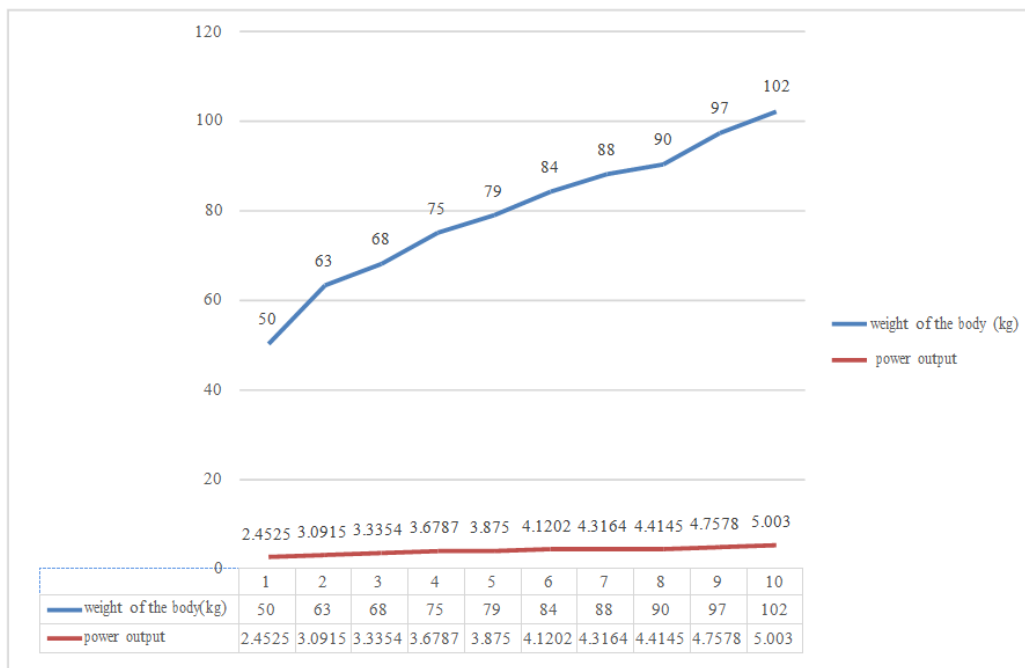

Fig. 3. Graph of weight induced against power generated

5. RECOMMENDATION

The following recommendations have been drawn based on the knowledge we have acquired from the design and construction of this project and personal observations in the course of the work.

- To make it more portable using required materials such as rack and pinion.
- Rubbers should be used to finish the surface in order to reduce vibrations.
- The use of required metals (rubber surface finishing, rack and pinion) to withstand the pressure induced by human on the pressure plate.
- This project would be beneficial to the society in installed in public and crowded areas such as markets, airports, parks, train stations among others.

COMPETING INTERESTS

Authors has declared that no competing interests exist.

REFERENCES

1. Rohatgi Prateek, Alare Kehinde, Alare Taiwo. Renewable Energy; 2020. DOI;10.13140/RG.2.2.32751.87201
2. Alare Taiwo Efficiency and thermoeconomic optimization of solar powered steam boiler and turbine: Renewable Power Source And Energy Economics; 2020.DOI:10.13140/RG.2.2.27101.13281
3. Adeniji EE, Asonja TO, Alare T. (2022). Design of a heating chamber for air turbines: A method of optimizing its efficiency. Journal of Energy Research and Reviews. 2022;11(1),48-53. Available:<https://doi.org/10.9734/jenrr/2022/v11i1302>
4. Akinnawo Olanrewaju, Alare Taiwo. Development of an eco-efficient automatic paper cutting machine using reverse manufacturing. International Journal of Engineering Management and Economics. 2021;1301 DOI:10.35629/5252-030813011306
5. Alare Taiwo. Material; Waste; Energy and Environment; 2022. DOI;10.13140/RG.2.2.35351.04005
6. Shrinath Bhosle. Non-conventional energy using foot step by converting mechanical energy into the electrical energy, department of mechanical engineering, proceeding of ncriet & Indian J. Sci. Res.2015;12(1):p332-343
7. Jose Ananth Vino. "Power Generation Using Foot Step", International Journal of Engineering Trends and Technology (IJETT Volume1 Issue2); 2011.
8. Tom krupenkin, Ashley Taylor J. "Reverse electro wetting as a new approach to high power energy harvesting" Nature communication. 2011;1-7
9. Patel Kamlesh, Pandya Krunal, Patel Ronak, Prajapati Jaydeep, Mr. Sorathiya Mehul. 2018;4(5). Print ISSN: 2395-1990 | Online ISSN : 2394-4099
10. Jose V, Ananth vino. (2011) Power generation using foot step, Journal:- volume 1, issue 2
11. Vicker JJ, Pennock GR, Shigley JE. Theory of machines and mechanisms. New York: Oxford University Press; 2003.
12. "An Investigation on Generation of Electricity Using Foot Step"; 2015. Available:<https://learnmech.com/foot-path-electricity-generation-system/>
13. Sclater Neil. Chain and belt devices and mechanisms. Mechanisms and Mechanical Devices Sourcebook. 5th ed. New York: McGraw Hill. 2011;262–277.

APPENDIX

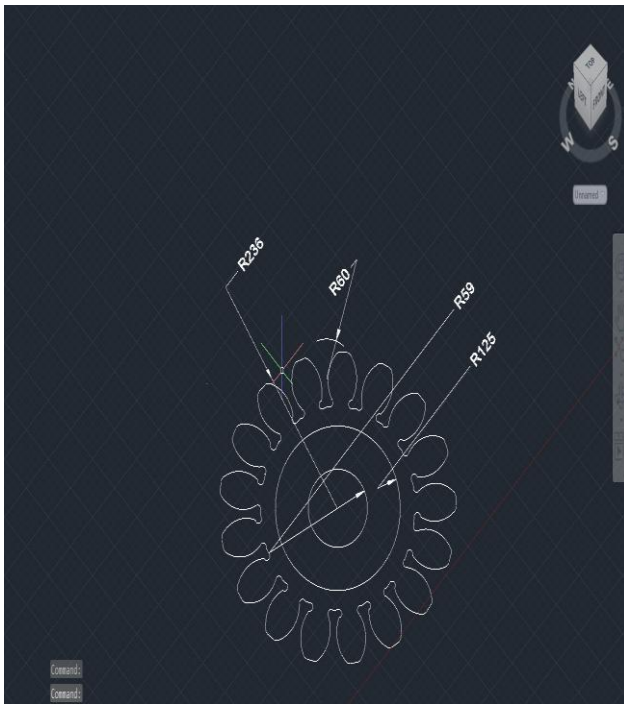

Orthographic diagram of a sprocket

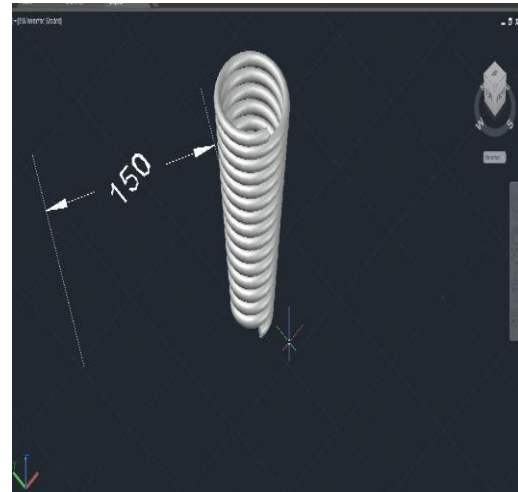

Orthographic diagram of a Helical spring

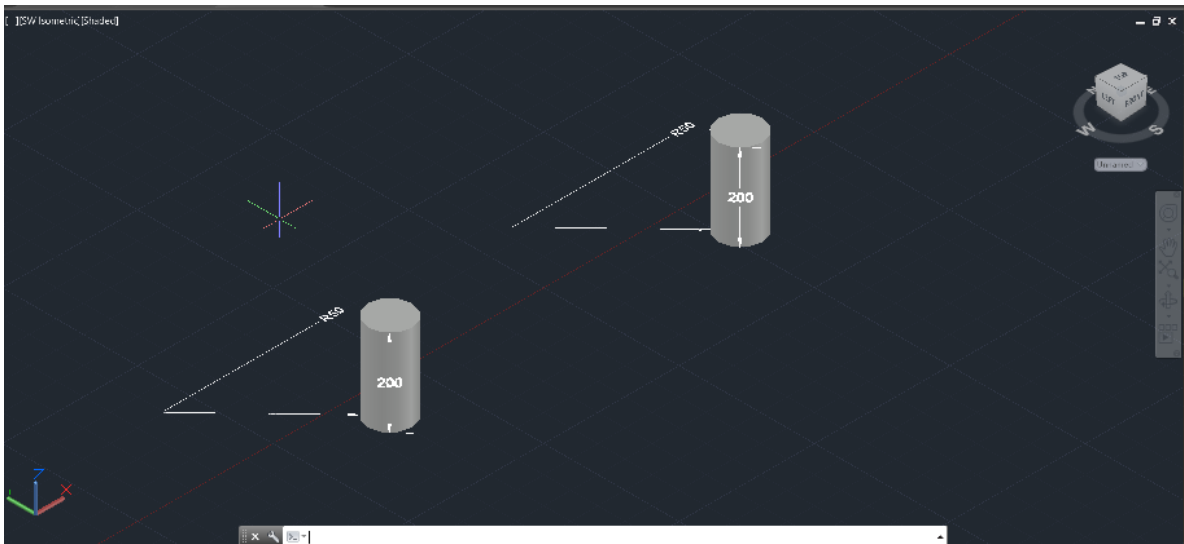

Orthographic diagram of Steel rods

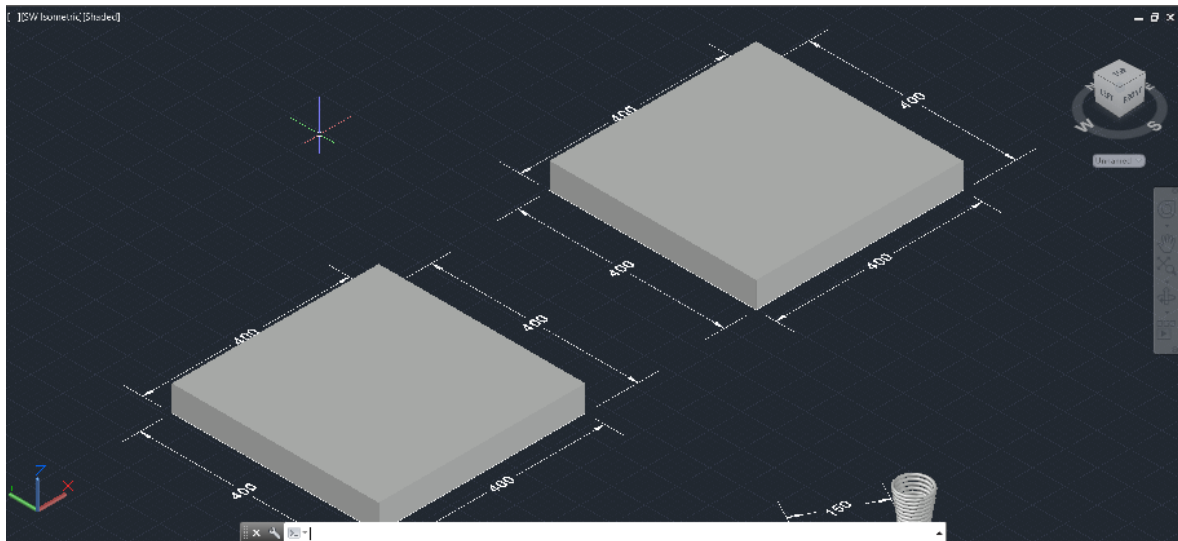

Orthographic diagram of a Pressure and base plate



Footstep power generation system



Foot placed on the pressure plate of the footstep power generation system

© 2023 Abadah; This is an Open Access article distributed under the terms of the Creative Commons Attribution License (<http://creativecommons.org/licenses/by/4.0>), which permits unrestricted use, distribution, and reproduction in any medium, provided the original work is properly cited.

Peer-review history:

*The peer review history for this paper can be accessed here:
<https://www.sdiarticle5.com/review-history/93991>*